

**RANKIN**

**NORTHSTAR**

## SPIN WEEDERS

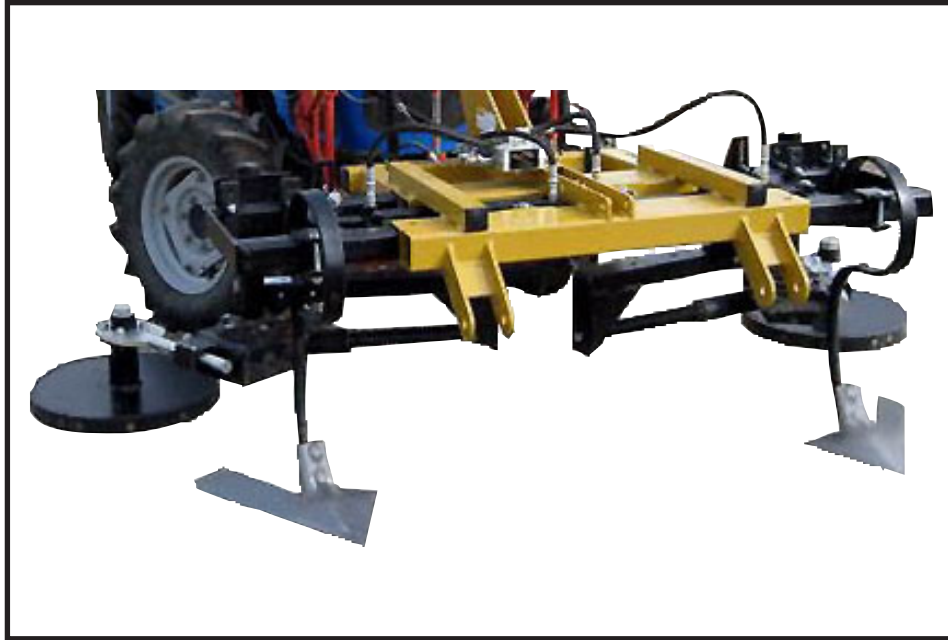

SET UP, OPERATION & PARTS MANUAL

2011 Models

# TABLE OF CONTENTS

<b>SECTION</b>	<b>DESCRIPTION</b>	<b>PAGE</b>
<b>1</b>	<b>Introduction .....</b>	<b>1</b>
1.1	Operator's Responsibility.....	1
<b>2</b>	<b>Safety.....</b>	<b>2-4</b>
2.1	General Safety .....	3
2.2	Equipment Safety Guidelines.....	4
<b>3</b>	<b>Set-Up &amp; Assembly .....</b>	<b>5</b>
3.1	Setting Spin Weeders Spring Tension .....	5
3.2	Setting The Overall Width.....	5
3.3	Placement of 18" Half Sweeps .....	5
3.4	Placement of Spin Weeder .....	5
3.5	Lubrication .....	5
<b>4</b>	<b>Parts Lists .....</b>	<b>6 - 8</b>
4.1	3-Pt. Adjustable Frame Assembly .....	6
4.2	3-Point Frame Assembly.....	7
4.3	KW-1800 RH/LH Spin Weeder Assy .....	8 - 10
4.4	S Tine Assembly .....	11
4.5	Coulter Assembly .....	12
4.6	Gauge Wheel Assembly.....	13
4.7	Parking Stand Assembly.....	14
4.8	KW-3D Disc Assembly.....	15
<b>5</b>	<b>Limited Warranty .....</b>	<b>16</b>

# 1 INTRODUCTION

Congratulations on your choice of our Spin Weeder. This equipment has been designed and manufactured to meet the needs of a discriminating buyer for the efficient control of weeds without the use of chemicals. The Spin Weeders come with 2 different mounting systems - Fixed frames, and hydraulic adjustable frames from 8' to 12' rows. The fixed and hydraulic frames are available in rear tractor mount.

## 1.1 OPERATOR'S RESPONSIBILITY

Safe, efficient and trouble free operation of your Spin Weeder requires that you and anyone else who will be operating or maintaining the machine, read and understand the Safety, Operation, Maintenance and Troubleshooting information contained within the Operator's Manual.

Keep this manual handy for frequent reference and to pass on to new operators or owners. Call your •••••••••••••••••••• dealer if you need assistance, information or additional copies of the manuals.

**OPERATOR ORIENTATION** - The directions left, right, front and rear, as mentioned throughout this manual, are as seen from the driver's seat and facing in the direction of travel.

### CUSTOMER INFORMATION

**NAME:** \_\_\_\_\_

**PURCHASED FROM:** \_\_\_\_\_

**DATE OF PURCHASE:** \_\_\_\_\_

**MODEL NUMBER:** \_\_\_\_\_

**SERIAL NUMBER:** \_\_\_\_\_

### SAFETY ALERT SYMBOL

This Safety Alert symbol means **ATTENTION! BECOME ALERT! YOUR SAFETY IS INVOLVED!**

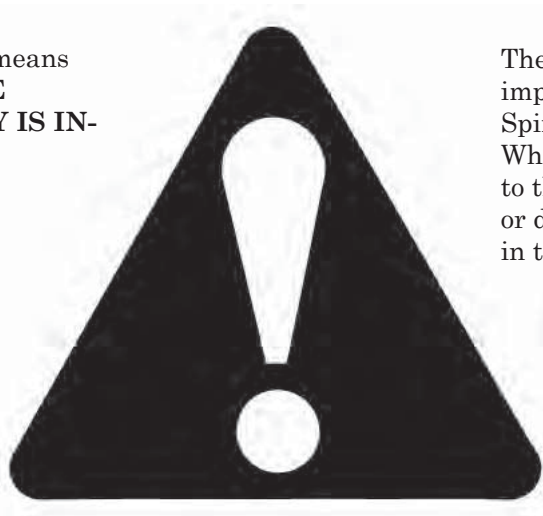

The Safety Alert symbol identifies important safety messages on the Spin Weeder and in the manual. When you see this symbol, be alert to the possibility of personal injury or death. Follow the instructions in the safety message.

Why is SAFETY important to you?

#### 3 Big Reasons

**Accidents Disable and Kill**  
**Accidents Cost**  
**Accidents Can Be Avoided**

#### SIGNAL WORDS:

Note the use of the signal words **DANGER**, **WARNING** and **CAUTION** with the safety messages. The appropriate signal word for each message has been selected using the following guide-lines:

**SI NO LEE INGLES, PIDA AYUDA A AIGUIEN QUE SI LO LEA PARA QUE LE TRADUZCA LAS MIDIDAS DE SEGURIDAD.**

**DANGER** - Indicates an imminently hazardous situation that, if not avoided, will result in death or serious injury. This signal word is to be limited to the most extreme situations typically for machine components which, for functional purposes, cannot be guarded.

**WARNING** - Indicates a potentially hazardous situation that, if not avoided, could result in death or serious injury, and includes hazards that are exposed when guards are removed. It may also be used to alert against unsafe practices.

**CAUTION** - Indicates a potentially hazardous situation that, if not avoided, may result in minor or moderate injury. It may also be used to alert against unsafe practices.

If you have any questions not answered in this manual or require additional copies or the manual is damaged, please contact your dealer.

## 2.1 GENERAL SAFETY

**YOU** are responsible for the **SAFE** operation and maintenance of your Spin Weeder. **YOU** must ensure that you and anyone else who is going to operate, maintain or work around the Spin Weeder be familiar with the operating and maintenance procedures and related **SAFETY** information contained in this manual. This manual will take you step-by-step through your working day and alerts you to all good safety practices that should be adhered to while operating the Spin Weeder.

Remember, **YOU** are the key to safety. Good safety practices not only protect you, but also the people around you. Make these practices a working part of your safety program. Be certain that **EVERYONE** operating this equipment is familiar with the recommended operating and maintenance procedures and follows all the safety precautions. Most accidents can be prevented. Do not risk injury or death by ignoring good safety practices.

- Spin Weeder owners must give operating instructions to operators or employees before allowing them to operate the machine, and at least annually there after per OSHA (Occupational Safety and Health Administration) regulation 1928.57.
- The most important safety feature on this equipment is a **SAFE** operator. It is the operator's responsibility to read and understand **ALL** Safety and Operating instructions in the manual and to follow these. Most accidents can be avoided.
- A person who has not read and understood all operating and safety instructions is not qualified to operate the machine. An untrained operator exposes himself and bystanders to possible serious injury or death.
- **DO NOT** modify the equipment in any way. Unauthorized modification may impair the function and/or safety and could affect the life of the equipment.
- **Think SAFETY! Work SAFELY!**

1. Read and understand the Operator's Manual and all safety signs before operating, maintaining adjusting or unplugging the Spin Weeder.



2. Have a first-aid kit available for use should the need arise and know how to use it.



3. Have a fire extinguisher available for use should the need arise and know how to use it.



4. Wear appropriate protective gear. This list includes but is not limited to:

- A hard hat
- Protective shoes with slip resistant soles
- Protective goggles, glasses or face shield
- Heavy gloves
- Protective clothing

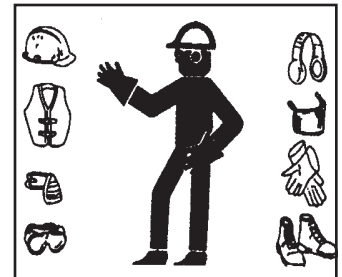

5. Install and secure all guards before starting.

6. **DO NOT** allow riders.



7. Wear suitable ear protection for prolonged exposure to excessive noise.

8. Place all controls in neutral, stop tractor engine, set park brake, remove ignition key and wait for all moving parts to stop before servicing, adjusting, repairing, or unplugging.

9. Clear the area of people, especially small children, before starting.

10. Review safety related items annually with all personnel who will be operating or maintaining the Spin Weeder.

## 2.2 EQUIPMENT SAFETY GUIDELINES

Safety of the operator and bystanders is one of the main concerns in designing and developing a machine. However, every year many accidents occur which could have been avoided by a few seconds of thought and a more careful approach to handling equipment. You, the operator, can avoid many accidents by observing the following precautions in this section. To avoid personal injury or death, study the following precautions and insist those working with you, or for you, follow them.

- In order to provide a better view, certain photographs or illustrations in this manual may show an assembly with a safety shield removed. However, equipment should **never** be operated in this condition. Keep all shields in place. If shield removal becomes necessary for repairs, replace the shield prior to use.
- Replace any safety sign or instruction sign that is not readable or is missing. Location of such safety signs is indicated in this manual.
- **NEVER** use alcoholic beverages or drugs which can hinder alertness or coordination while operating this equipment. Consult your doctor about operating this machine while taking prescription medications.
- **Under no circumstances should young children be allowed to work with this equipment. Do not allow persons to operate or assemble this unit until they have read this manual and have developed a thorough understanding of the safety precautions and of how it works.** Review the safety instructions with all users annually.
- This equipment is dangerous to children and persons unfamiliar with its operation. The operator should be a responsible, properly trained and physically able person familiar with farm machinery and trained in this equipment's operations. If the elderly are assisting with farm work, their physical limitations need to be recognized and accommodated.
- Use a tractor equipped with a Roll Over Protective Structure (ROPS) and a seat belt.
- **NEVER** exceed the limits of a piece of machinery. If its ability to do a job, or to do so safely, is in question - **DON'T TRY IT.**
- Do not modify the equipment in any way. Unauthorized modification may impair the function and/or safety and could affect the life of the equipment.

In addition to the design and configuration of this implement, including Safety Signs and Safety Equipment, hazard control and accident prevention are dependent upon the awareness, concern, prudence and proper training of personnel involved in the operation, transport, maintenance and storage of the machine. Refer also to Safety Messages and operation instruction in each of the appropriate sections of the tractor and machine manuals. Pay close attention to the Safety Signs affixed to the tractor and the machine.

**Think SAFETY! Work SAFELY!**

## 3 SET-UP - DOUBLE SPIN WEEDERS

### 3.1 SETTING SPIN WEEDERS SPRING TENSION

1. It is not possible to preset the spin weeder's spring tension at the factory for your field conditions. The amount of tension will vary based on how hard the ground and how deep you are weeding. The spring pressure should be enough to lift the weeds out of the ground and roll around the plant base.
2. If you feel the spring tension is too aggressive for your conditions, just loosen the spring screw to reduce the pressure.
3. If you feel the wheel does not have enough tension, just tighten the spring.

### 3.2 SETTING THE OVERALL WIDTH

1. If you only have one spin weeder, the overall width is not as important, just position the tractor so that the outer edge of the weeder wheel is just beyond the row line.
2. If you have a double spin weeder (right and left hand), the overall width of the unit should be first set at approximately 4 inches wider than your row width.

### 3.3 SETTING THE PLACEMENT OF THE 18" HALF SWEEPS

1. Set the 18" half sweep with the long end facing out.
2. Set the 18" half sweep no more than half way under the spin weeder wheel. If you find that you are moving too much soil, move the half sweep so that you are covering approximately  $\frac{1}{4}$  of the wheel.
3. If you are still moving too much soil, remove the half sweeps.

**NOTE:** If your soil is loose, you may not require the half sweeps. If your soil is very hard or rocky, we suggest using the 18" diameter coulter. For added depth control of the spin weeder head, you may want to use the coulter with depth band.

### 3.4 SETTING THE SPIN WEEDER IN THE FIELD

1. The spin weeder wheel is bolted approximately 3 inches above the 18" half sweep.
2. To start with, have 10 threads showing on the spring shaft. Then loosen if too much tension on the spring or tighten if more tension is required. **WARNING:** Do not "bottom out" the spring tension, as you could damage the spin weeder.
3. Tilt the spin weeder wheel down in front approximately 2 degrees. If you want to maintain the berm, set the angle approximately 7 degrees.
4. Set the spin weeders approximately 4" on each side beyond the row line. Just the "spring back" going through the soil will pull back the spin weeder wheel, usually in a couple of inches. When going through the soil you will want the spin weeders no more than 2" beyond the row line. In most cases, you need to dig into the soil approximately 2" which is figured from the bottom of the wheels. If your berm is higher, it is possible to go deeper.
5. In order for the spin weeder to operate correctly the berm needs to be at least 2" high so that the spring is not in tension at all times. If the soil is extremely hard, it may be necessary to make two passes until you can get beyond the row line. Once you loosen the hard soil, the next time you weed it will not be necessary to make two passes.

Always start "spin weeding" at slower tractor speed of 2 to 3 M.P.H. until you are comfortable with the unit. Then increase to the recommended speed of 5 to 7 miles per hour.

### 3.5 LUBRICATION

The spin weeder wheel hubs should have a couple shots of grease every 50 hours.

From time to time, we recommend spraying the spring and shaft with industrial spray lubricate.

# 4 PARTS LISTS

## 4.1 3-POINT ADJUSTABLE FRAME ASSEMBLIES

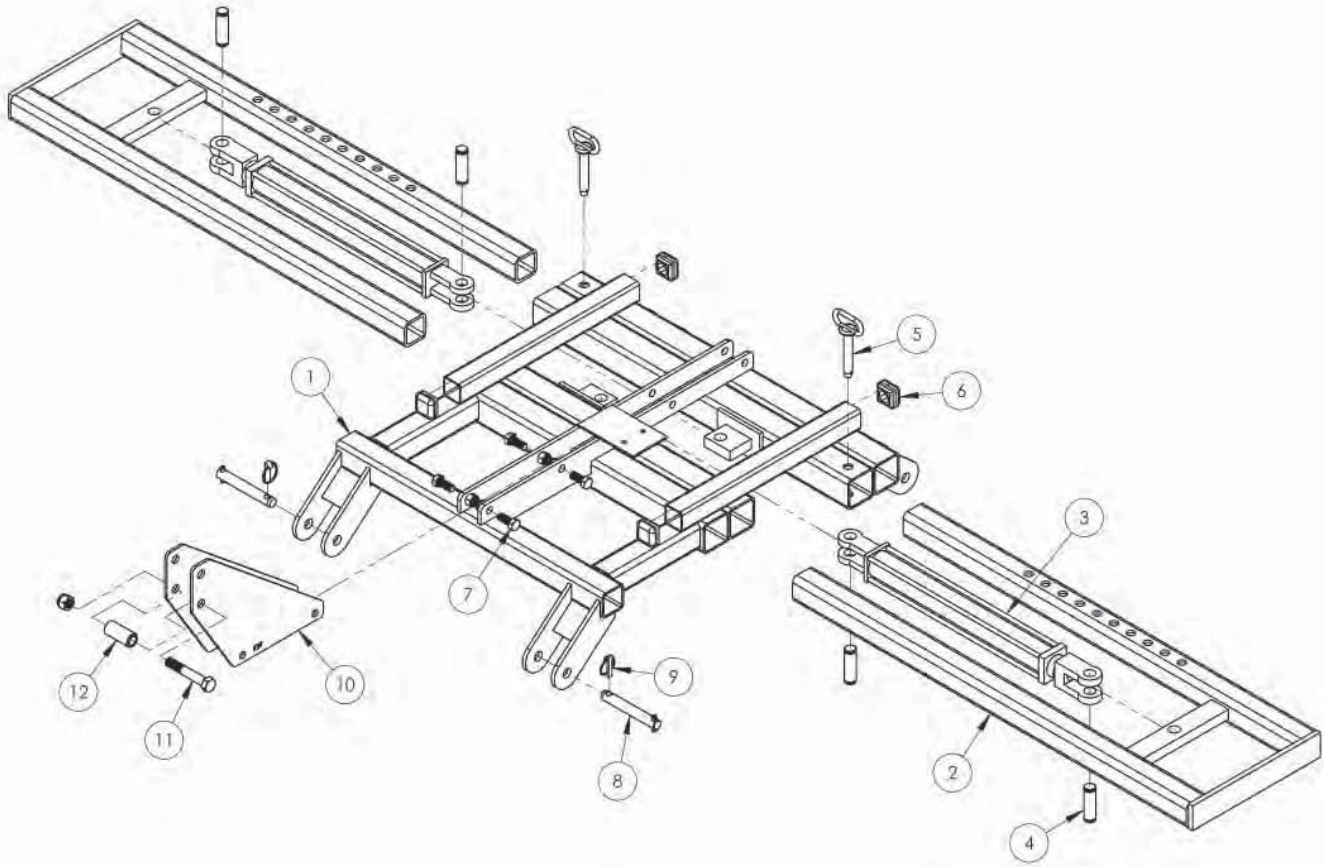

<u>REF.</u>	<u>QTY.</u>	<u>PART NO.</u>	<u>DESCRIPTION</u>
1	1	KW-2400-SW-FRAME	Main Frame Weldment
2	2	KW-2410	Slide Weldment (2400 Series Only)
	2	KW-2410-1	Slide Weldment (2500 Series Only, not shown)
3	2	2X18-CYL	2" x 18" Hydraulic Cylinder
	4	KW-0302	2404-6-6 Straight Adapter (not shown)
4	4	HR-0317	Cylinder Pin w/Keepers
6	4	KW-0150	2" Square Plastic Cap
7	4	007-101-1	5/8" x 1 1/2" Gr. 5 NC Cap Screw w/Nylock Nut
8	2	P7234	Cat. 1 Clevis Pin
9	2	P791	7/16" Lynch Pin
10	2	CP-0160-B	Top Link Plate
11	1	007-212-1	3/4" x 4 1/2" Gr. 5 NC Cap Screw w/Nylock Nut
12	1	CP-0164	Top Link Bushing 2 3/4"
	2	KW-0300	3/8" Hose - 94" Cut Length (not shown)
	2	KW-0301	3/8" Hose - 78" Cut Length (not shown)
	4	HR-0276	8010-4 Male Quick Disconnect (not shown)
	2	KW-PS	Adjustable Parking Stand (not shown)



## 4 PARTS LISTS (CONTINUED)

### 4.2 3-POINT FRAME ASSEMBLIES

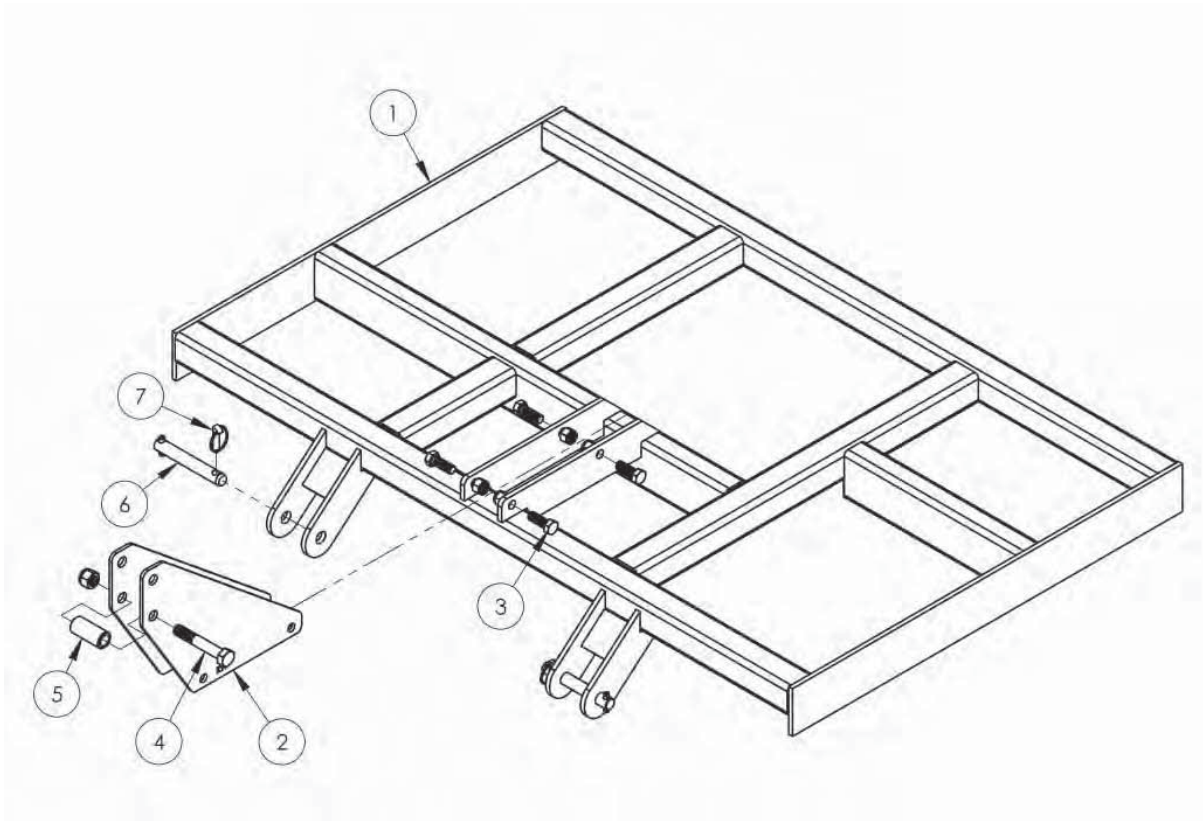

<u>REF.</u>	<u>QTY.</u>	<u>PART NO.</u>	<u>DESCRIPTION</u>
1	1	KW-2300-4	4' Frame Weldment (not shown)
1	1	KW-2300-5	5' Frame Weldment
1	1	KW-2300-6	6' Frame Weldment (not shown)
1	1	KW-2300-7	7' Frame Weldment (not shown)
1	1	KW-2300-8	8' Frame Weldment (not shown)
2	2	CP-0160-B	Top Link Plate
3	4	007-102-1	$\frac{5}{8}$ " x 1 $\frac{3}{4}$ " Gr. 5 NC Cap Screw w/Nylock Nut
4	1	007-212-1	$\frac{3}{4}$ " x 4 $\frac{1}{2}$ " Gr. 5 NC Cap Screw w/Nylock Nut
5	1	CP-0164	top Link Bushing 2 $\frac{3}{4}$ "
6	2	P7234	Cat. 1 Clevis Pin
7	2	P791	$\frac{7}{16}$ " Lynch Pin

## 4 PARTS LISTS (CONTINUED)

### 4.3 KW-1800 RH/LH SPIN WEEDER ASSEMBLY

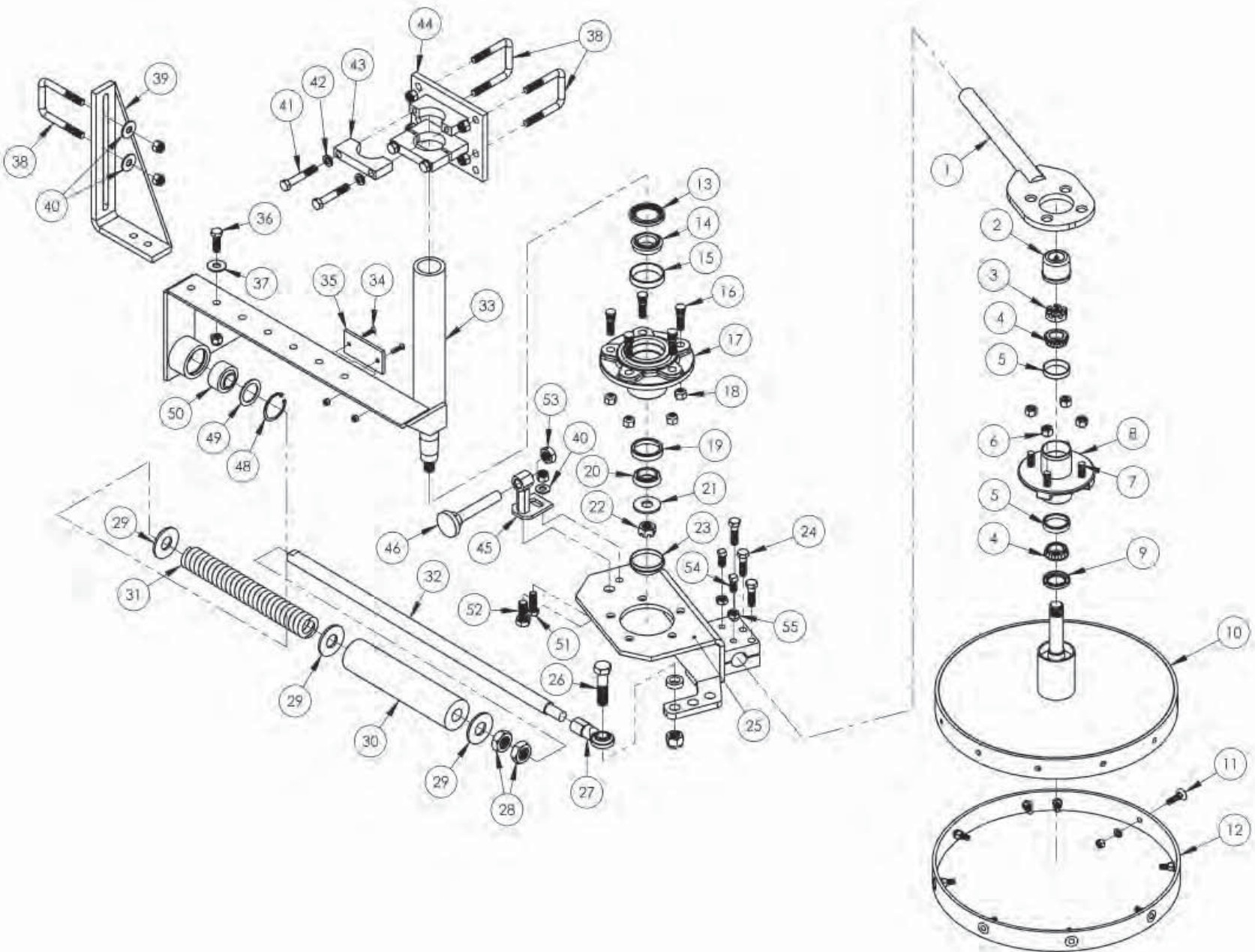

## 4 PARTS LISTS (CONTINUED)

### 4.3 KW-1800 RH/LH SPIN WEEDER ASSY PART NUMBERS

<u>REF.</u>	<u>QTY.</u>	<u>PART NO.</u>	<u>DESCRIPTION</u>
1	1	KW-2120	Arm Weldment
2	1	TR-884	Sure Lube Grease Cap
3	1	3167	1" Slotted Nut (HR-0403)
4	2	3164	Bearing L44643 (HR-0386)
5	2	3165	Race L44610 (HR-0387)
6	4	3170	½" Lug Nut
7	4	KW-0148	½" NF Stud
8	1	KW-2111	Hub Grp Complete w/Brgs, Races, Cap, Seal & Lug Nuts (3-100-04-50)
9	1	3163	Hub Seal (HR-0385) (SL-122-1)
	1	3168	Cotter Pin (not shown) (HR-0384)
10	1	KW-2110	Head Weldment
11	12	024-705-1	⅜" x 1 ¼" NC Flat Head Socket Capscrew w/Hex Nut & Lockwasher
12	1	KW-0140	¼" UHMW Wear Strip
13	1	G-SL-175	Bearing Seal (RTM SL-175)
14	1	G-LM48548	Inner Spindle Bearing LM48548
15	1	G-LM48510	Inner Bearing Race LM48510
16	5	G-ST-504	½" - 20 NF - 2 ¼" Stud
17	1	HR-2654	Hub w/Studs, Bearings and Seal
18	5	G-STN-509	½" - 20 NF Lug Nut
19	1	HR-0377	Outer Baring Race LM67010
20	1	HR-0376	Outer Spindle Bearing LM67048
21	1	HR-0382	¾" Spindle Washer (RTM SW-750)
22	1	HR-0381	Spindle Nut ¾" NF Slotted (RTM SN-750)
	1	HR-0384	Cotter Pin ⅝" x 1 ½" (not shown)
23	1	HR-0375	Grease Cap
24	3	007-003-2	½" x 1 ½" Gr. 5 NC Cap Screw
25	1	KW-2100A	Right Hand Pivot Bracket Weldment
	1	KW-2101A	Left Hand Pivot Bracket Weldment (not shown)
26	1	007-207-1	¾" x 3 Gr. 5 NC Cap Screw w/Nylock Nut
27	1	KW-0147	¾" NF Greaseable Ball Joint
28	2	057-110-2	1" x -14 NF Hex Jam Nut
29	3	TR-670	1" USS Flat Washer
30	1	KW-0120	Polyurethane Bumper Cushion
31	1	KW-0145	Compression Spring - 12 ¾" Long
32	1	KW-0130	Guide Shaft
33	1	KW-2130	Right Hand Pivot Weldment
	1	KW-2131	Left Hand Pivot Weldment (not shown)
34	2	133-406-1	¼" x 1" NC Slotted Flat Head Machine Screw w/Nylock Nut
35	1	KW-0135	UHMW ¼" x 2" -- 4" Long
36	1	007-003-1	½" x 1 ½" Gr. 5 NC Cap Screw w/Nylock Nut
37	5	TR-668	½" SAE Flat Washer

## 4 PARTS LISTS (CONTINUED)

### 4.3 KW-1800 RH/LH SPIN WEEDER ASSY PART NUMBERS (CONTINUED)

<u>REF.</u>	<u>QTY.</u>	<u>PART NO.</u>	<u>DESCRIPTION</u>
38	3	BB-0135	½" x 2 ½" x 4" NC U-bolt w/Nylock Nuts
39	1	KW-2150-A	Anchor Bracket
40	3	068-6-1	½" USS Flat Washer
41	4	007-009-1	½" x 3" Gr. 5 NC Cap Screw
42	4	072-011-1	½" Lock Washer
43	2	KW-0100	Pivot Clamp Block
44	1	KW-2140	Pivot Clamp Base
45	1	KW-0155	Pivot Mount
46	1	KW-0156	Adjustable Stop
48	1	KW-0112	Internal Snap Ring
49	1	KW-0116	Machined Washer
50	1	KW-0113	Shaft Bearing, 1"
51	1	007-003-1	½" x 1 ½" Gr. 5 NC Cap Screw w/Nylock Nut
52	1	007-101-1	⅝" x 1 ½" Gr. 5 NC Cap Screw
53	1	057-108-1	¾" NC Jam Nut
54	2	153774	½ - 20 x 1" Square Head Set Screw - Cup Point
55	2	057-105-2	½ - 20 NF Hex Jam Nut

## 4 PARTS LISTS (CONTINUED)

### 4.4 S TINE ASSEMBLY

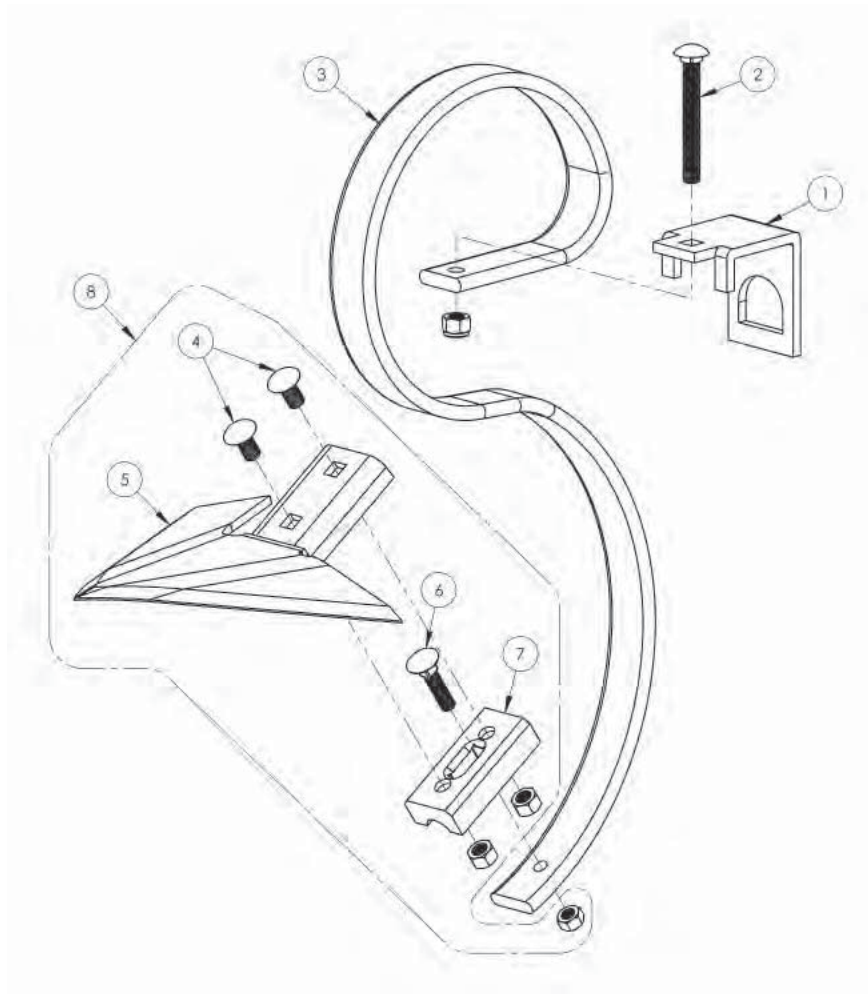

<b>REF.</b>	<b>QTY.</b>	<b>PART NO.</b>	<b>DESCRIPTION</b>
1	1	1209840	S-Tine Clamp For 2 ½" Square Tube
2	1	016-307-1	½" x 4" NC Gr. 5 Carriage Bolt w/Nylock Nut
3	1	1208252	Heavy S-Tine 45 x 12 x 660
4	2	016-299-1	½" x 1" NC Gr. 5 Carriage Bolt w/Hex Nut
5	1	KW-0118-RH	Right Hand 18" Sweep
5	1	KW-0118-LH	Left Hand 18" Sweep
6	1	014-103-1	⅞" x 2 ¼" NC Plow Bolt w/Hex Nut
7	1	KW-0146	Sweep Adapter
8		KW-18RH	Right Hand Sweep & Adapter Assembly
8		KW-18LH	Left Hand Sweep & Adapter Assembly

## 4 PARTS LISTS (CONTINUED)

### 4.5 COULTER ASSEMBLY

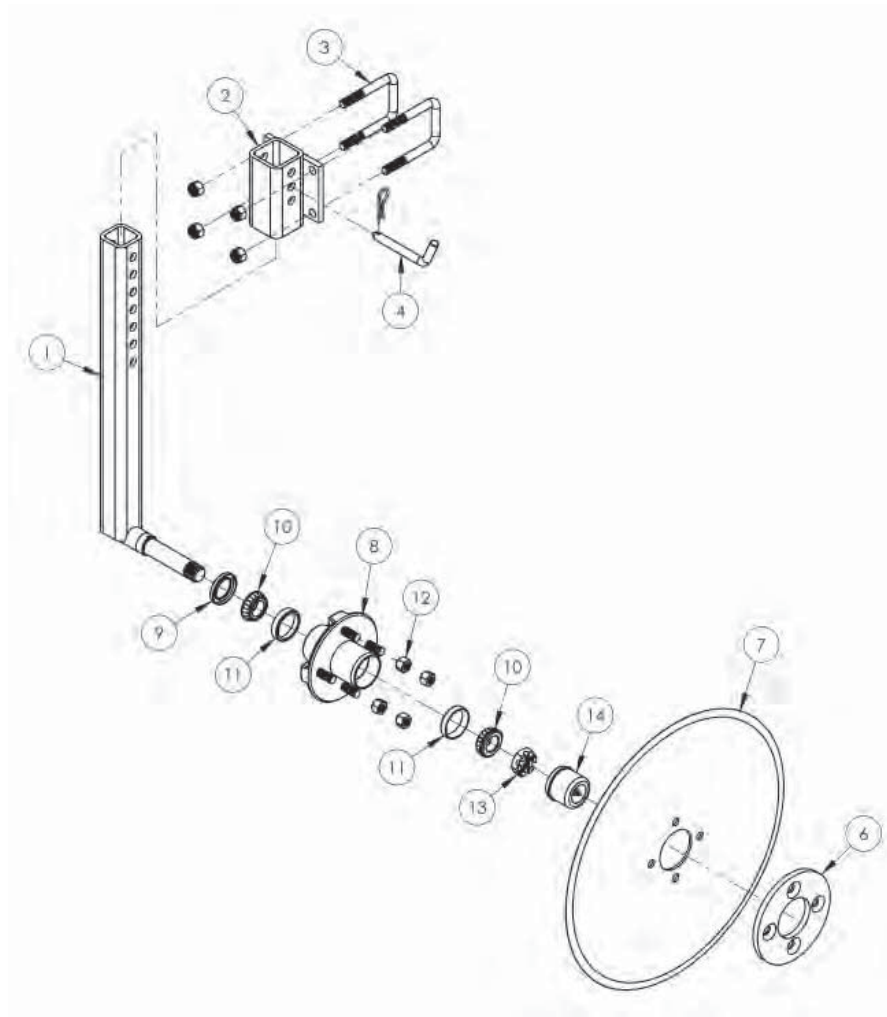

<u>REF.</u>	<u>QTY.</u>	<u>PART NO.</u>	<u>DESCRIPTION</u>
1	1	KW-C-100	Coulter Spindle Arm
2	1	KW-GW-100	Gauge Wheel Pocket
3	2	BB-0135	½" x 2 ½" x 4" NC U-Bolt w/Nylock Nuts
4	1	P71111	½" Pin w/Keeper
6	1	KW-C-101	Support Plate
7	1	KW-C-102	18" Coulter
8	1	KW-2111	Hub Group Complete w/Bearings, Races, Cap, Seal & Lug Nuts (3-100-04-50)
9	1	3163	Hub Seal (HR-0385) (SL-122-1)
10	2	3164	Bearing L44643 (HR-0386)
11	2	3165	Race L44610 (HR-0387)
12	5	3170	½" Lug Nut
13	1	3167	1" Slotted Nut (HR-0403)
	1	3168	Cotter Pin (not shown) (HR-0384)
14	1	TR-884	Sure Lube Cap

## 4 PARTS LISTS (CONTINUED)

### 4.6 GAUGE WHEEL ASSEMBLY

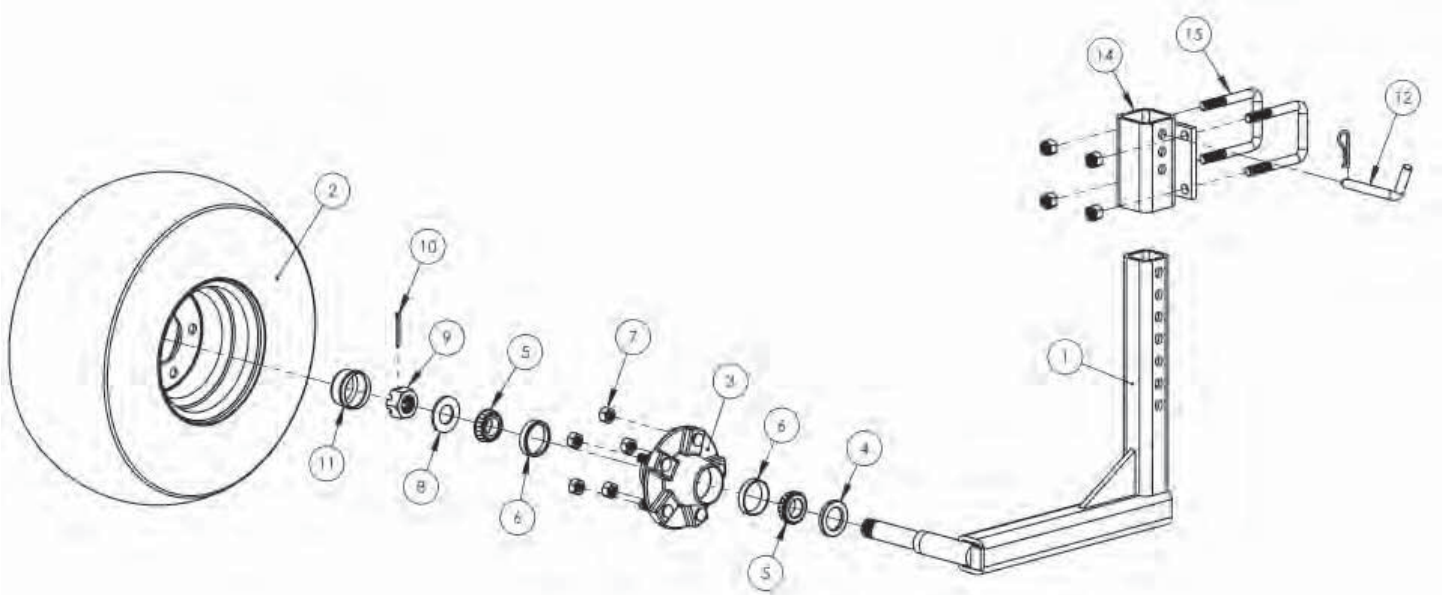

<u>REF.</u>	<u>QTY.</u>	<u>PART NO.</u>	<u>DESCRIPTION</u>
1	1	KW-GW-101	Gauge Wheel Spindle Arm Weldment
2	1	3160	18.5 x 8.5 Wheel & Tire
3	1	3161	545 Hub w/Bearings, Races, Seal, Cap & Lug Nuts
4	1	3163	Hub Seal (HR-0385) (SL-122-1)
5	2	3164	Bearing L44643 (HR-0386)
6	2	3165	Race L44610 (HR-0387)
7	5	3170	½" Lug Nut
8	1	3166	Washer
9	1	3167	1" Slotted Nut (HR-0403)
10	1	3168	Cotter Pin (HR-0384)
11	1	3169	Grease Cap
12	1	P71111	½" Pin w/Keeper
14	1	KW-GW-100	Gauge Wheel Pocket
15	2	BB-0135	½" x 2 ½" x 4" NC U-bolt w/Nylock Nuts

## 4 PARTS LISTS (CONTINUED)

### 4.7 PARKING STAND ASSEMBLY

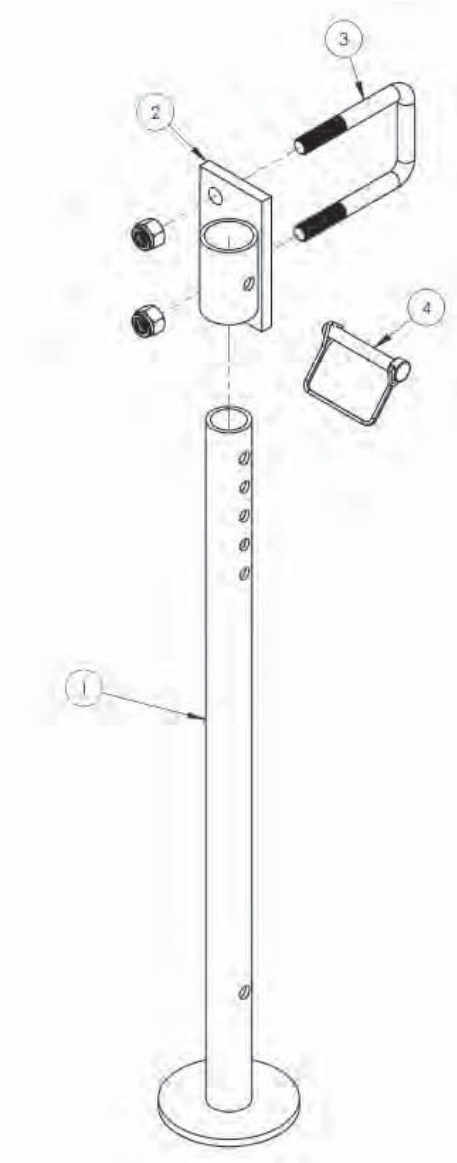

<u>REF.</u>	<u>QTY.</u>	<u>PART NO.</u>	<u>DESCRIPTION</u>
1	1	CP-PS-23.5-A	Parking Stand Weldment
2	1	KW-PS-100	Clamp On Pocket
3	1	BB-0135	½" x 2 ½" x 4" NC U-bolt w/Nylock Nuts
4	1	P7940	PTO Pin



# KW-3D DISC ASSEMBLY

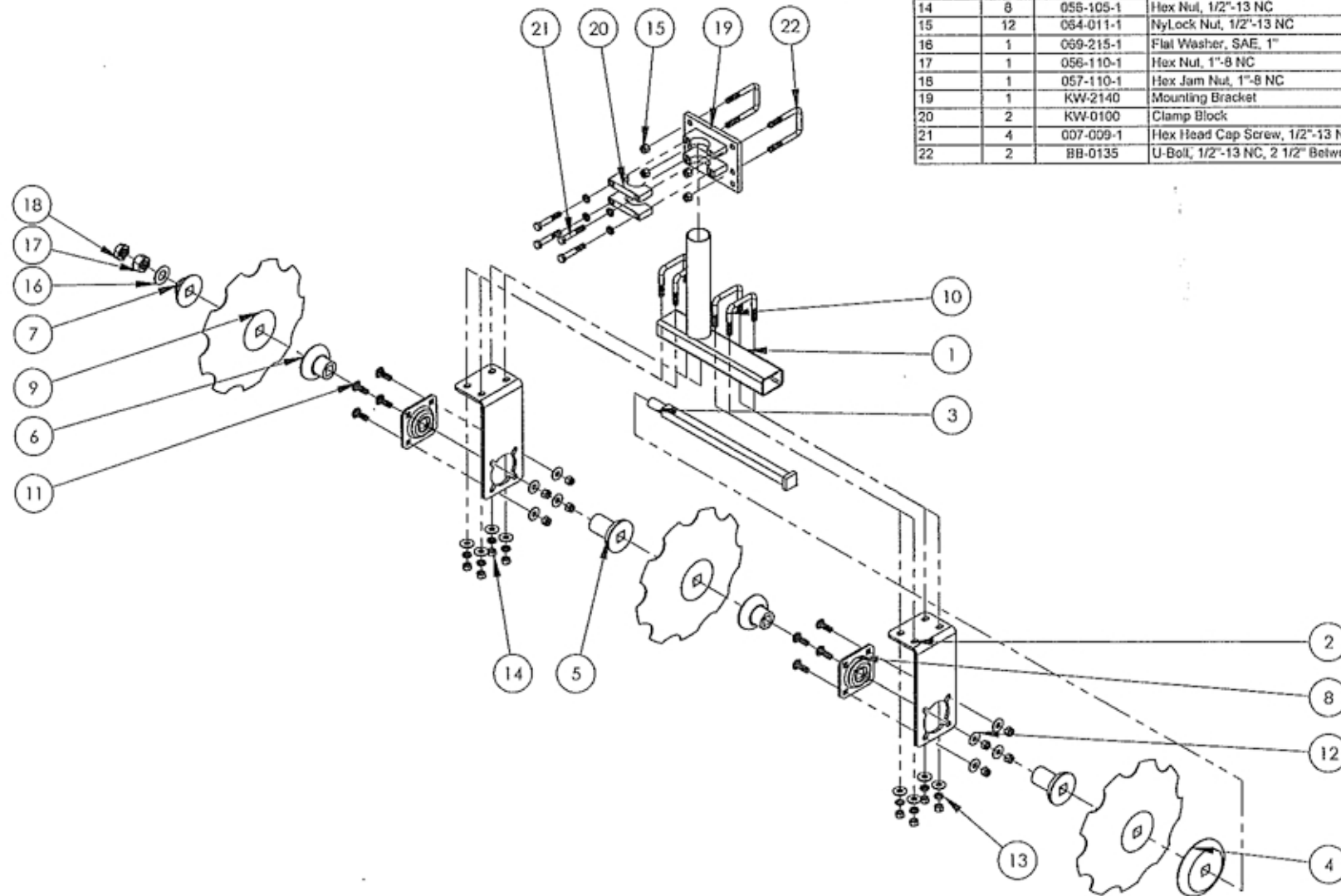

ITEM NO.	QTY.	PART NUMBER	DESCRIPTION
1	1	KW-3D-101	Disc Gang Carrier
2	2	KW-3D-100	Hanger Bracket
3	1	KW-44621	1" Sq x 18 1/2" Axle
4	1	KW-10255	Bumper Washer for 1" Axle
5	2	KW-36779	Spacer 3 5/8"
6	2	KW-36246	Spacer 2 3/8"
7	1	KW-38069	End Washer for 1" Axle
8	2	KW-45109	Bearing 1" Sq (ST208)
9	3	KW-38091	Notched Disc Blade 14" Dia. 1" Sq
10	4	156-206-1	U-Bolt, 1/2"-13 NC, 3" Between Legs, 3" Inside Length
11	8	016-301-1	Carriage Bolt, 1/2"-13 NC X 1 1/2"
12	16	068-006-1	Flat Washer, 1/2" USS
13	12	072-011-1	Lock Washer, 1/2"
14	8	056-105-1	Hex Nut, 1/2"-13 NC
15	12	064-011-1	NyLock Nut, 1/2"-13 NC
16	1	069-215-1	Flat Washer, SAE, 1"
17	1	056-110-1	Hex Nut, 1"-8 NC
18	1	057-110-1	Hex Jam Nut, 1"-8 NC
19	1	KW-2140	Mounting Bracket
20	2	KW-0100	Clamp Block
21	4	007-009-1	Hex Head Cap Screw, 1/2"-13 NC X 3"
22	2	BB-0135	U-Bolt, 1/2"-13 NC, 2 1/2" Between Legs, 4" Inside Length

**RANKIN****NORTHSTAR**

## LIMITED WARRANTY

RANKIN EQUIPMENT/NORTHSTAR ATTACHMENTS warrants each new RANKIN/NORTHSTAR product to be free from defects in material and workmanship for a period of twelve (12) months from date of purchase to the original purchaser. This warranty shall not apply to implements or parts that have been subject to misuse, negligence, accident, or that have been altered in any way.

Our obligation shall be limited to repairing or replacement of any part, provided that such part is returned within thirty (30) days from date of failure to RANKIN/NORTHSTAR through the dealer from whom the purchase was made, transportation charges prepaid.

This warranty shall not be interpreted to render us liable for injury or damages of any kind or nature, direct, consequential or contingent, to person or property. This warranty does not extend to loss of crops, loss because of delay in harvesting or any other expenses, for any other reasons.

RANKIN/NORTHSTAR in no way warrants engines, tires, or other trade accessories, since these items are warranted separately by these respective manufacturers.

RANKIN/NORTHSTAR reserves the right to make improvements in design or changes in specification at any time, without incurring any obligations to owners or units previously sold.

RANKIN EQUIPMENT/NORTHSTAR ATTACHMENTS  
3205 BAY STREET  
UNION GAP, WA 98903

Always refer to and heed machine operating warning decals on machine.



P.O. Box 168  
Yakima, WA 98907-0168

Phone: 509.453.8271  
Fax: 509.457.2456

[www.rankinequipment.com](http://www.rankinequipment.com)

P.O. Box 1937  
Yakima, WA 98907-1937

Phone: 509.452.1651  
Fax: 509.457-6601

[www.northstarattachments.com](http://www.northstarattachments.com)

3205 Bay Street, Union Gap, WA 98903



P.O. Box 168  
Yakima, WA 98907-0168

Phone: 509.453.8271  
Fax: 509.457.2456

[www.rankinequipment.com](http://www.rankinequipment.com)

P.O. Box 1937  
Yakima, WA 98907-1937

Phone: 509.452.1651  
Fax: 509.457-6601

[www.northstarattachments.com](http://www.northstarattachments.com)

3205 Bay Street, Union Gap, WA 98903